

City of Arnold, Missouri

---

Council Meeting  
Council Chamber

April 21, 2016  
7:00 p.m.

---

**Amended Agenda**

1. Pledge of Allegiance:
2. Opening Prayer: First Baptist Church of Arnold – Assoc. Pastor Brad Bean
3. Roll Call
4. Business from the Floor:
5. Consent Agenda
  - A. Minutes from **April 7, 2016**.
  - B. Special Meeting Minutes from **April 14, 2016**
  - C. Payroll Warrant **#1236 in the Amount of \$253,658.66**
  - D. General Warrant **#5664 in the Amount of \$651,445.99**
6. Ordinances:

**None**
7. Resolutions:
  - A. **Resolution No. 16-25:** A Resolution Approving a Settlement Agreement Between the City of Arnold and Gander Mountain Company and Authorizing the Mayor to Execute said Settlement Agreement.
  - B. **Resolution No. 16-26:** A Resolution Authorizing the Mayor to Enter Into an Agreement with All-Inclusive Rec.
  - C. **Resolution No. 16-27:** A Resolution Appointing Andrew Sutton to the Police Personnel Board.
  - D. **Resolution No. 16-28:** A Resolution Granting a Cooley-Fulbright Beautification Grant to the River Bluffs Estates Subdivision.

8. Motion
9. Reports from Mayor, Council, and Committees:
10. Administrative Reports
11. Adjournment

Mayor Ron Counts called the meeting to order at 7:00 p.m.

The Pledge of Allegiance was recited.

Pastor Steve Majdecki from New Hope United Methodist Church offered the opening prayer.

Those present per roll call taken by City Clerk Tammi Casey: Mayor Ron Counts, Crisler, Fulbright, Freese, Amato, Plunk, Owens, McArthur, Cooley, Richison, Casey, Holden, Sweeney, Boone, Blattner, Kroupa and Chief Shockey.

#### **BUSINESS FROM THE FLOOR**

NONE

#### **CONSENT AGENDA**

- A. MINUTES FROM THE MARCH 17, 2016 MEETING**
- B. PAYROLL WARRANT NO. 1234 IN THE AMOUNT OF \$249,924.43**
- C. PAYROLL WARRANT NO. 1235 IN THE AMOUNT OF \$262,206.67**
- D. GENERAL WARRANT NO. 5663 IN THE AMOUNT OF \$733,509.79**

**Jason Fulbright made a motion and so moved to approve the consent agenda.** Seconded by Nancy Crisler. Roll call vote: Crisler, yes; Fulbright, yes; Freese, yes; Amato, yes; Plunk, yes; Owens, yes; McArthur, yes; Cooley, yes; 8 Yeas: **Consent agenda approved.**

#### **ORDINANCES**

NONE

## RESOLUTIONS

### **RESOLUTION NO. 16-17 – A RESOLUTION AUTHORIZING THE MAYOR TO ENTER INTO A CONTRACT WITH ZIMMERMAN ELECTRIC**

Bryan Richison reminded council that this resolution was tabled from a previous meeting. Due to extenuating circumstances, this project will be re-bid. Before that can happen, the original resolution must be voted on first to complete the process.

**Paul Freese made a motion and so moved to approve Resolution No. 16-17. Seconded by Jason Fulbright.** Roll call vote: Crisler, no; Fulbright, no; Freese, no; Amato, no; Plunk, no; Owens, no; McArthur, no; Cooley, no; 0 Yeas; 8 Nays; **Resolution Failed.**

### **RESOLUTION NO. 16-19 – A RESOLUTION AUTHORIZING THE MAYOR TO ENTER INTO A CONTRACT WITH J.M. MARSCHUETZ CONSTRUCTION COMPANY TO PROVIDE CONSTRUCTION SERVICES FOR THE RESIDENTIAL CITY WIDE CONCRETE STREET REPLACEMENT PROJECT FOR THE CITY OF ARNOLD**

**Brian McArthur made a motion and so moved to approve Resolution No. 16-19.** Seconded by David Owens. Roll call vote: Crisler, yes; Fulbright, yes; Freese, yes; Amato, yes; Plunk, yes; Owens, yes; McArthur, yes; Cooley, yes; 8 Yeas: **Resolution passed.**

### **RESOLUTION NO. 16-20 – A RESOLUTION AUTHORIZING THE MAYOR TO ENTER INTO A CHANGE ORDER WITH J.M. MARSCHUETZ CONSTRUCTION COMPANY TO PROVIDE CONSTRUCTION SERVICES FOR THE RESIDENTIAL CITY WIDE CONCRETE STREET REPLACEMENT PROJECT FOR THE CITY OF ARNOLD**

**Paul Freese made a motion and so moved to approve Resolution No. 16-20.** Seconded by Jason Fulbright. Roll call vote: Crisler, yes; Fulbright, yes; Freese, yes; Amato, yes; Plunk, yes; Owens, yes; McArthur, yes; Cooley, yes; 8 Yeas: **Resolution passed.**

### **RESOLUTION NO. 16-21 – A RESOLUTION APPOINTING AARON BEAN TO THE VETERANS COMMITTEE TO COMPLETE AN UNEXPIRED TWO-YEAR TERM**

**Butch Cooley made a motion and so moved to approve Resolution No. 16-21.** Seconded by Gary Plunk. Roll call vote: Crisler, yes; Fulbright, yes; Freese, yes; Amato, yes; Plunk, yes; Owens, yes; McArthur, yes; Cooley, yes; 8 Yeas: **Resolution passed.**

**RESOLUTION NO. 16-22 – A RESOLUTION AUTHORIZING THE MAYOR TO ENTER INTO A CONTRACT WITH CONTRACTORS AND MUNICIPAL SWEEPING SERVICES FOR THE CITY OF ARNOLD**

**Butch Cooley made a motion and so moved to approve Resolution No. 16-22.** Seconded by Jason Fulbright. Roll call vote: Crisler, yes; Fulbright, yes; Freese, yes; Amato, yes; Plunk, yes; Owens, yes; McArthur, yes; Cooley, yes; 8 Yeas: **Resolution passed.**

**RESOLUTION NO. 16-23 – A RESOLUTION AUTHORIZING THE MAYOR TO ENTER INTO A CONTRACT WITH GATEWAY FIREWORKS**

**Nancy Crisler made a motion and so moved to approve Resolution No. 16-23.** Seconded by Paul Freese. Roll call vote: Crisler, yes; Fulbright, yes; Freese, yes; Amato, yes; Plunk, yes; Owens, yes; McArthur, yes; Cooley, yes; 8 Yeas: **Resolution passed.**

**MOTIONS**

NONE

**REPORTS FROM MAYOR, COUNCIL AND COMMITTEES**

**Mayor Counts** – Thanked the outgoing council (Nancy Crisler and Paul Freese) for all of their hard work. Mayor Counts stated they both have served the City and their wards well.

All council members and staff during their reports thanked both Nancy Crisler and Paul Freese for all of their hard work and dedication to the City while serving on the council.

**Nancy Crisler – Ward 1** – Stated that she has enjoyed serving the City for the past 2 ½ years. Ms. Crisler thanked the council and staff for all they have taught her and she will treasure the experience. Ms. Crisler also congratulated E.J. Fleischmann for winning the election in Ward 1.

**Gary Plunk – Ward 4** – Stated that the Tourism Committee will be funding a 27 hole golf tournament to be held on June 25<sup>th</sup>. The proceeds will go to the Missouri Humane Society.

**Paul Freese – Ward 3** – Congratulated the newly elected. Mr. Freese stated the decision not to run this year was a tough one, but felt it was time to take a break after over eight years of serving the City. Mr. Freese thanked council and staff for their hard work and support over the years and stated it has been a very rewarding experience.

**Butch Cooley – Ward 4** – Asked Ed Blattner for an update regarding brush pick up.

**Phil Amato – Ward 3** – Spoke regarding an idea he stated he would like to see given serious consideration, which is possibility of annexing the Fox Schools outside city limits which include Ridgewood, Simpson and Lonedell. Mr. Amato asked that a study be prepared for the annexation of not only the schools but the surrounding areas adjacent to the schools. Mr. Amato then brought David McArthur to the microphone to provide an update on the Veterans Commission. Mr. McArthur invited everyone to attend their meeting on April 20<sup>th</sup> where they will distribute certificates of appreciation for volunteers that served on the commission's Flag Initiative.

**Jason Fulbright – Ward 1** – Presented gifts to Nancy Crisler and Paul Freese in appreciation of their service.

**Brian McArthur – Ward 2** – Thanked the residents of Ward 2 for re-electing him to the council.

## ADMINISTRATIVE REPORTS

**Chief Shockey** – Informed council that he currently has 6 vehicles that need to be certified as surplus so that he can sell them. **Paul Freese made a motion and so moved to certify 6 police vehicles as surplus.** Seconded by Nancy Crisler. Roll call vote: Crisler, yes; Fulbright, yes; Freese, yes; Amato, yes; Plunk, yes; Owens, yes; McArthur, yes; Cooley, yes; 8 Yeas: **Motion passed.**

Chief Shockey stated that the cost to have forensics studies performed on cell phones has gotten very expensive and is increasing to approximately \$7500 per year. The number of companies that sell the equipment that enables the police department to perform the work themselves is very limited. He has received prices for the equipment from two companies. The cost ranges from \$9995 to \$11,084 to purchase the equipment. He would like to use drug forfeiture money to purchase the equipment from the lowest priced company. Bob Sweeney informed council that since the cost to purchase the equipment is under \$10,000, normal bidding procedures could be waived. **Paul Freese made a motion and so moved to allow the Police Department to use drug forfeiture money to purchase the cell phone forensics equipment in the amount of \$9995.** Seconded by Nancy Crisler. Roll call vote: Crisler, yes; Fulbright, yes; Freese, yes; Amato, yes; Plunk, yes; Owens, yes; McArthur, yes; Cooley, yes; 8 Yeas: **Motion passed.**

5  
Regular Meeting  
April 7, 2016

**Bob Sweeney** – Encouraged council members to pay careful attention to all MML updates, as the Missouri legislature is engaging in a series of proposals that could handcuff local government.

A motion to adjourn the meeting was made by Jason Fulbright. Seconded by Nancy Crisler. Voice vote: All yeas.

Meeting adjourned at 7:43 p.m.

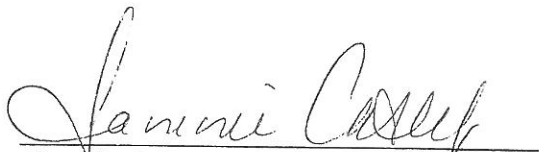
  
City Clerk Tammi Casey, MRCC

CITY OF ARNOLD, MISSOURI

ROLL CALL

MEETING: REGULAR

DATE: 4/7/2016

PAGE: 1

BILL NO - RESOLUTION - MOTION

		ROLL CALL	CONSENT AGENDA	RESOLUTION NO. 16-17	RESOLUTION NO. 16-19	RESOLUTION NO. 16-20	RESOLUTION NO. 16-21
<b>COUNCIL MEMBERS:</b>							
MAYOR	RON COUNTS	PRESENT					
COUNCIL:	NANCY CRISLER	PRESENT	YES	NO	YES	YES	YES
COUNCIL:	JASON FULBRIGHT	PRESENT	YES	NO	YES	YES	YES
COUNCIL:	PAUL FREESE	PRESENT	YES	NO	YES	YES	YES
COUNCIL:	PHIL AMATO	PRESENT	YES	NO	YES	YES	YES
COUNCIL:	GARY PLUNK	PRESENT	YES	NO	YES	YES	YES
COUNCIL:	DAVID OWENS	PRESENT	YES	NO	YES	YES	YES
COUNCIL:	BRIAN MCARTHUR	PRESENT	YES	NO	YES	YES	YES
COUNCIL:	BUTCH COOLEY	PRESENT	YES	NO	YES	YES	YES
CITY ADMINISTRATOR	BRYAN RICHISON	PRESENT	PARKS DIR:		SUSIE BOONE	PRESENT	
CITY CLERK	TAMMI CASEY	PRESENT	PUBLIC WORKS:		ED BLATTNER	PRESENT	
COM DEV	MARY HOLDEN	PRESENT	TREASURER:		DAN KROUPA	PRESENT	
CITY ATTORNEY	BOB SWEENEY	PRESENT	POLICE DEPT.		CHIEF SHOCKEY	PRESENT	



CITY OF ARNOLD, MISSOURI

ROLL CALL

MEETING: REGULAR

DATE: 4/7/2016

PAGE: 2

BILL NO - RESOLUTION - MOTION

		RESOLUTION NO. 16-22	RESOLUTION NO. 16-23	MOTION TO CERTIFY 6 POLICE VEHICLES AS SURPLUS	MOTION TO USE DRUG FORFEITURE MONEY TO PURCHASE FORENSIC EQUIPMENT		
<b>COUNCIL MEMBERS:</b>							
<b>MAYOR</b>	RON COUNTS						
<b>COUNCIL:</b>	NANCY CRISLER	YES	YES	YES	YES		
<b>COUNCIL:</b>	JASON FULBRIGHT	YES	YES	YES	YES		
<b>COUNCIL:</b>	PAUL FREESE	YES	YES	YES	YES		
<b>COUNCIL:</b>	PHIL AMATO	YES	YES	YES	YES		
<b>COUNCIL:</b>	GARY PLUNK	YES	YES	YES	YES		
<b>COUNCIL:</b>	DAVID OWENS	YES	YES	YES	YES		
<b>COUNCIL:</b>	BRIAN MCARTHUR	YES	YES	YES	YES		
<b>COUNCIL:</b>	BUTCH COOLEY	YES	YES	YES	YES		
<b>CITY ADMINISTRATOR</b>	BRYAN RICHISON			<b>PARKS DIR:</b>	SUSIE BOONE		
<b>CITY CLERK</b>	TAMMI CASEY			<b>PUBLIC WORKS:</b>	ED BLATTNER		
<b>COM DEV</b>	MARY HOLDEN			<b>TREASURER:</b>	DAN KROUPA		
<b>CITY ATTORNEY</b>	BOB SWEENEY			<b>POLICE DEPT.</b>	CHIEF SHOCKEY		

Mayor Ron Counts called the special meeting to order at 7:00 p.m.

Those present per roll call taken by City Clerk Tammi Casey: Mayor Ron Counts, Plunk, Amato, Owens, Fleischmann, McArthur, Sullivan, Cooley, Fulbright, Richison (excused), Casey, Holden, Sweeney (excused), Boone, Blattner, Kroupa and Chief Shockey.

## **ORGANIZATION OF COUNCIL**

### **A. ELECTION OF MAYOR PRO-TEM**

Mayor Counts opened the floor to nominations.

Gary Plunk nominated Jason Fulbright. Butch Cooley nominated Phil Amato. Phil Amato declined the nomination for Mayor Pro-Tem. As there were no other names offered, Mayor Counts closed nominations. Jason Fulbright, by acclamation is elected as Mayor Pro-Tem.

### **B. MAYORAL COMMITTEE APPOINTMENTS**

The mayoral committee appointments are attached and hereto made part of this record.

**Vern Sullivan made a motion and so moved to approve the mayoral committee appointments.** Seconded by Gary Plunk. Roll call vote: Plunk, yes; Amato, yes; Owens, yes; Fleischmann, yes; McArthur, yes; Sullivan, yes; Cooley, yes; Fulbright, yes; 8 Yeas: **Motion carried.**

## **RESOLUTIONS**

### **RESOLUTION NO. 16-24 – A RESOLUTION AUTHORIZING THE MAYOR TO ENTER INTO A CONTRACT WITH REINHOLD ELECTRIC. INC.**

**Gary Plunk made a motion and so moved to approve Resolution No. 16-24.** Seconded by Brian McArthur. Roll call vote: Plunk, yes; Amato, yes; Owens, yes; Fleischmann, yes; McArthur, yes; Sullivan, yes; Cooley, yes; Fulbright, yes; 8 Yeas: **Resolution approved.**

2  
Special Meeting  
April 14, 2016

A motion to adjourn the meeting was made by Vern Sullivan. Seconded by Gary Plunk.  
Voice vote: All Yeas.

Meeting adjourned at 7:05 p.m.

---

City Clerk Tammi Casey, MRCC

Draft

CITY OF ARNOLD, MISSOURI

ROLL CALL

MEETING: SPECIAL MEETING

DATE: 4/14/2016

PAGE: 1

BILL NO - RESOLUTION - MOTION

		ROLL CALL	MOTION TO APPROVE MAYORAL COMMITTEE APPOINTMENTS	RESOLUTION NO. 16-24			
<b>COUNCIL MEMBERS:</b>							
<b>MAYOR</b>	<u>RON COUNTS</u>	PRESENT					
<b>COUNCIL:</b>	<u>GARY PLUNK</u>	PRESENT	YES	YES			
<b>COUNCIL:</b>	<u>PHIL AMATO</u>	PRESENT	YES	YES			
<b>COUNCIL:</b>	<u>DAVID OWENS</u>	PRESENT	YES	YES			
<b>COUNCIL:</b>	<u>E J FLEISCHMANN</u>	PRESENT	YES	YES			
<b>COUNCIL:</b>	<u>BRIAN MCARTHUR</u>	PRESENT	YES	YES			
<b>COUNCIL:</b>	<u>VERN SULLIVAN</u>	PRESENT	YES	YES			
<b>COUNCIL:</b>	<u>BUTCH COOLEY</u>	PRESENT	YES	YES			
<b>COUNCIL:</b>	<u>JASON FULBRIGHT</u>	PRESENT	YES	YES			
<b>CITY ADMINISTRATOR</b>	<u>BRYAN RICHISON</u>	EXCUSED	<b>PARKS DIR:</b>	<u>SUSIE BOONE</u>			PRESENT
<b>CITY CLERK</b>	<u>TAMMI CASEY</u>	PRESENT	<b>PUBLIC WORKS:</b>	<u>ED BLATTNER</u>			PRESENT
<b>COM DEV</b>	<u>MARY HOLDEN</u>	PRESENT	<b>TREASURER:</b>	<u>DAN KROUPA</u>			PRESENT
<b>CITY ATTORNEY</b>	<u>BOB SWEENEY</u>	EXCUSED	<b>POLICE DEPT.</b>	<u>CHIEF SHOCKEY</u>			PRESENT

# MAYORAL

## COMMITTEE APPOINTMENTS 2016/2017

Planning Commission – Brian McArthur

Parks and Leisure Service Board – Gary Plunk / Butch Cooley

Police Pension Review Board - David Owens

Tourism Commission – Phil Amato

Commission on Aging & Disabilities – E. J. Fleischmann

Liquor Committee –Butch Cooley / Phil Amato / Vernon Sullivan

Finance/Budget Committee – Dan Kroupa, Ron Counts, Bryan Richison, Jason Fulbright, Ed Blattner, Brian McArthur

Farmers' Market Committee – E. J. Fleischmann

Economic Development Committee— Note: Mayor is still working on this committee.

Veterans Commission – Vernon Sullivan / Gary Plunk

Historic Preservation – Jason Fulbright

**The Liaison between the City and the Following Committees will be:**

Chamber of Commerce – Vernon Sullivan

Economic Development of Jefferson County – Bryan Richison

Jefferson County Municipal League – City Administrator / Bryan Richison

**RESOLUTION NO: 16-25**

**A RESOLUTION APPROVING A SETTLEMENT AGREEMENT BETWEEN THE CITY OF ARNOLD ("City") AND GANDER MOUNTAIN COMPANY ("Gander Mountain") AND AUTHORIZING THE MAYOR TO EXECUTE SAID SETTLEMENT AGREEMENT.**

---

WHEREAS, on or around February 24, 2009, developer Arnold Crossroads, L.L.C. ("Arnold Crossroads") filed suit against Gander Mountain in Jefferson County Circuit Court, in a lawsuit styled *Arnold Crossroads, L.L.C. v. Gander Mountain Company*, Case No. 09JECC00232 (the "Lawsuit"); and

WHEREAS, on or about November 4, 2011, the City intervened in the Lawsuit asserting claims against Gander Mountain; and

WHEREAS, on or about February 11, 2015, the Lawsuit resulted in a Judgment in favor of Gander Mountain; and

WHEREAS, on or about March 23, 2015, the City filed a Notice of Appeal, appealing the judgment to the Missouri Court of Appeals, Eastern District, in a lawsuit styled *Arnold Crossroads, L.L.C., Plaintiff City of Arnold, Intervenor-Appellant v. Gander Mountain Company, Defendant- Respondent* ED 102755 (the "Appeal"); and

WHEREAS, City and Gander Mountain wish to resolve the Appeal and the Lawsuit by execution of a settlement agreement by and between the parties; and

WHEREAS, City Mayor, Ron Counts, duly executed a settlement agreement ("Agreement"), attached hereto as Exhibit A, pursuant to the authority given by the City Council on December 3, 2015; and

WHEREAS, City, by this resolution, confirms approval of the Agreement; confirms Mayor Counts' authority to execute the Agreement; and ratifies Mayor Counts' signature on the attached Agreement;

NOW, THEREFORE, BE IT RESOLVED BY THE COUNCIL FOR THE CITY OF ARNOLD, MISSOURI, AS FOLLOWS:

Section 1. City Mayor, Ron Counts, is hereby authorized to execute the Agreement, attached hereto as Exhibit A, with Gander Mountain. This Agreement is incorporated herein by reference, for resolution, release and discharge of all

claims between the parties in consideration for payment of the sum of twenty-five thousand dollars (\$25,000.00) by Gander Mountain to City, and other good and valuable consideration and terms and conditions, as set forth in Exhibit A hereto.

Section 2. Mayor Counts' signature identified on Exhibit A is hereby ratified and the execution of the Agreement is deemed signed anew pursuant to the authorization granted by this resolution.

Section 3. This resolution shall provide written authority for Mayor Ron Counts to execute the Agreement pursuant to, and in compliance with all requirements of, R.S.Mo. 432.070. This resolution shall be in full force and effect from and after the date of its passage and approval.

\_\_\_\_\_  
Presiding Officer of the City Council

\_\_\_\_\_  
Mayor Ron Counts

ATTEST:

\_\_\_\_\_  
City Clerk Tammi Casey

Date: \_\_\_\_\_

April 15, 2016

Z:\CITYDOCS\RESOLUTN\16-25 Resolution\_Gander\_by\_Gander (2) 2016.rtf



*City of Arnold*  
*Susie Boone, Director of Parks*  
*and Recreation*  
*1695 Missouri State Road*  
*Arnold, MO 63010*

Date: April 14, 2016

To: Mayor, City Council, City Treasurer and City Adm.

From: Susie Boone, Director of Parks and Recreation

Subject: Picnic Tables

The department received six bids for picnic tables for Arnold City Park (due to the flood). Staff had estimated a cost of \$24,000 to FEMA and the bid from All-Inclusive is \$23,992.80.

We are recommending this low bid which meets all of our specifications.

Please contact me if you have any concerns or questions.



RESOLUTION NO: 16-26

A RESOLUTION AUTHORIZING THE MAYOR TO ENTER INTO  
AN AGREEMENT WITH ALL-INCLUSIVE REC

---

BE IT RESOLVED, by the Council of the City of Arnold, Missouri, that the Parks and Recreation Department, is hereby authorized to accept the bid of All-Inclusive Rec for picnic table replacements at the Arnold City Park.

A copy of said bid is attached hereto and made a part hereof reference.

\_\_\_\_\_  
Presiding Officer of the City Council

\_\_\_\_\_  
Mayor Ron Counts

ATTEST:

\_\_\_\_\_  
City Clerk Tammi Casey

Date: \_\_\_\_\_

**EXHIBIT A**

**BID FORM**

**PURCHASE AND DELIVERY OF PICNIC TABLES**

Please fill out this cost response form so that the City may accurately compare different bids without having to interpret vendor's cost presentations. If desired, attach additional cost data, including itemizations.

Company Name: All Inclusive Rec

Date: 4-6-2016

**Estimated Delivery Schedule is 2 Weeks from Receipt of Purchase Order**

**OPTION #1:**

Qty	Description	Price/unit	Total
55	Picnic Table 8' Treatable Wood Portable Bolt through/Walk through design	\$ <u>287.53</u>	\$ <u>15,814.15</u>
5	Picnic Table 8' ADA Compliant Treated Wood Blot through/Walk through design	\$ <u>287.53</u>	\$ <u>1437.65</u>
1	Delivery/Freight	\$ <u>Included</u>	\$ <u>Included</u>
Total OPTION #1			\$ <u>17,251.80</u>

**OPTION #2:**

Qty	Description	Price/unit	Total
15	Picnic Table 8' heavy duty recycled plastic Bolt through/Walk through design	\$ <u>399.88</u>	\$ <u>5998.20</u>
40	Picnic Table 8' Treatable Wood Portable Bolt through/Walk through design	\$ <u>399.88</u>	\$ <u>15995.20</u>
5	Picnic Table 8' ADA Compliant Treated Wood Blot through/Walk through design	\$ <u>399.88</u>	\$ <u>1999.40</u>
1	Delivery/Freight	\$ <u>Included</u>	\$ <u>Included</u>
Total OPTION #2			\$ <u>23,992.80</u>

SIGNATURES ON NEXT PAGE

The Undersigned understands and agrees that the City of Arnold may, at its discretion, elect to delete items, prior to award and issuance of purchase order.

The undersigned has examined the Specifications for the purchase and has satisfied himself as to the work to be done and the conditions under which it must be carried out.

NAME OF BUSINESS	All Inclusive Rec
(If an Individual) SIGNATURE OF BIDDER	
BUSINESS ADDRESS	PO Box 72, Farmington, MO 63640
TELEPHONE NO.	573-701-9787
(If Co-Partnership) FIRM NAME	N/A
SIGNATURE	
BUSINESS ADDRESS	
TELEPHONE NO.	
(If a Corporation) CORPORATE NAME	
SIGNATURE	
BUSINESS ADDRESS	
TELEPHONE NO.	



109 West Liberty • P.O. Box 72 • Farmington, Missouri 63640  
Phone: 573 701 9787 • Fax: 573 701 9312 • Toll Free 866 701 9787 • [air@allinclusiverec.com](mailto:air@allinclusiverec.com)

All Inclusive Rec LLC is a leading supplier of the highest quality Park and Playground products; and is centrally located in Farmington Missouri. A solution based organization representing brand names that are industry leaders, such as Little Tikes Commercial Playgrounds, Fibar Systems, SunPorts Shade Systems, and Sof Surfaces KrosLock Safety Surfaces; with local representation in Eastern Missouri, Central and Southern Illinois; and Iowa. Just some of the products we are able to offer you as a client.

Our commitment to superior client service is an everyday focus for everyone involved at All Inclusive Rec, making it easy for you a client to bring concepts to reality. Our goal is not just to meet your expectations, but exceed them.

All Inclusive Rec offers comprehensive site and installation service as well as playground planning and design services. And we proudly represent the following products:

- Commercial Playground Equipment by Little Tikes Commercial, 40+ years in business, Located in Monett Missouri
- Elephant Play Playground Equipment, 15+ years in the industry, Located in Quebec Canada
- Playground Safety Surface Systems and Materials
  - Fibar Systems (Engineered WoodFibre), 30 years experience, Corporate offices located in New York with distribution sites all over the United States.
  - Sof Surface Kroslock Safety Tiles, 16 years manufacturing tiles, Located in Ontario Canada
  - LandSoft Rubber Mulch
  - LandSoft Synthetic Turf
  - "Poured-in-Place" rubber surfacing By Duraplay, 25 years in the industry, Located in Wimberley Texas.
- Iron Mountain Forge Park Amenities, 40+ years in industry, Farmington Missouri
- Site Furnishings
- Sports Equipment by Gared Sports, 80+ years in the business, Located Locally in St. Louis Missouri
- Fabric Shade Solutions by Sun Ports, 19 years in the business, Located in Dallas Texas
- Shelters and Pavilions by RCP, 53 years in the business, Located in Stuart Florida

We welcome the opportunity to work with, and for you on your Inclusive Park and Playground project.

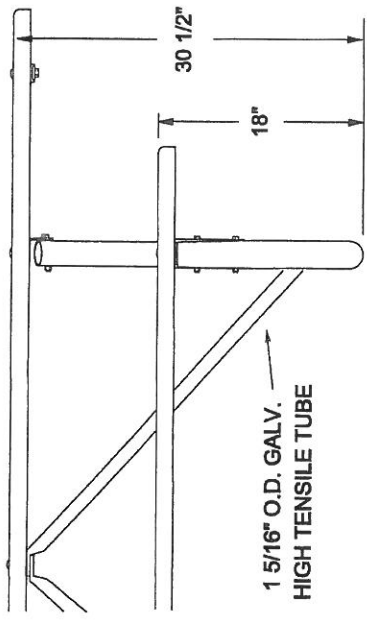
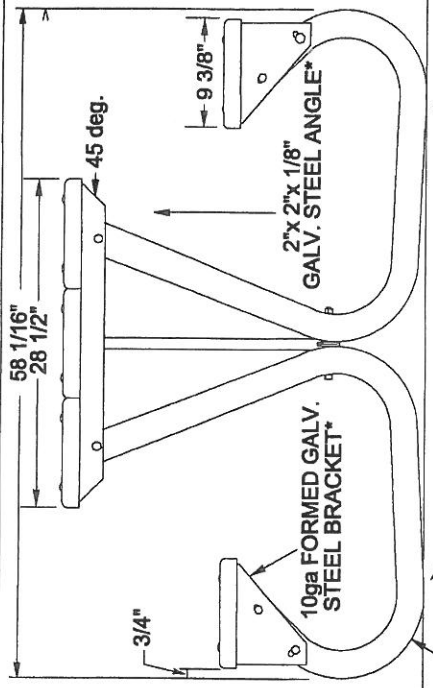

2 3/8" O.D. SCH 40 PIPE HOT DIP GALVANIZED AFTER FABRICATION

THE TABLE RESTS ON THE FOUR OUTSIDE CORNERS SO THAT IT WILL NOT ROCK ON UNEVEN GROUND.

\* SEAT BRACKET & TOP CLEAT ARE GALVANIZED AFTER FABRICATION TO ELIMINATE RAW EDGES LEFT WHEN USING PRE-GALV. SHEETS

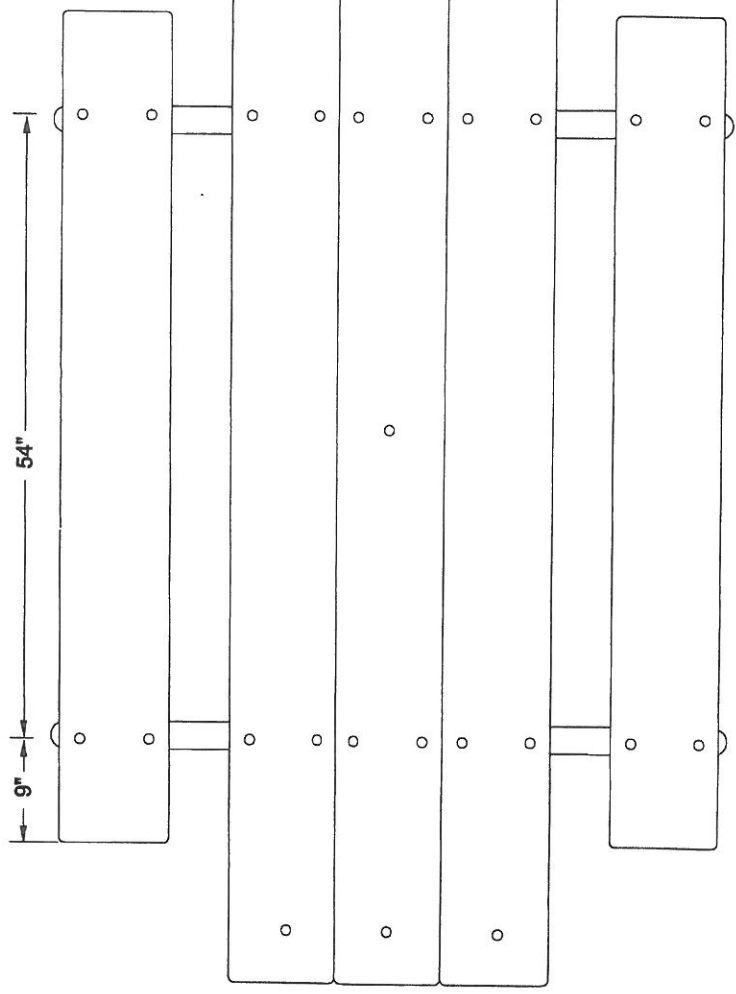

<b>KAY PARK</b>	
MODEL <b>82BGWHC</b>	WT. <b>218 lbs.</b>
DRAWN BY <b>CKB</b>	DATE <b>5/04</b>
SCALE <b>NONE</b>	

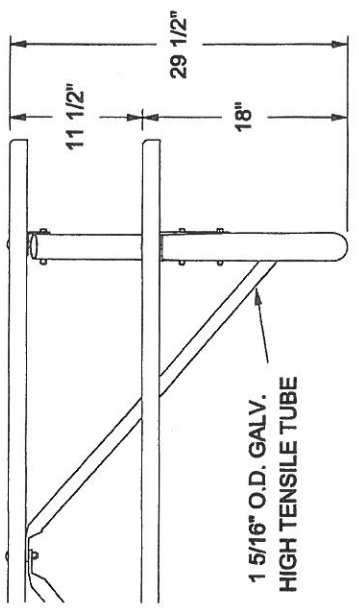
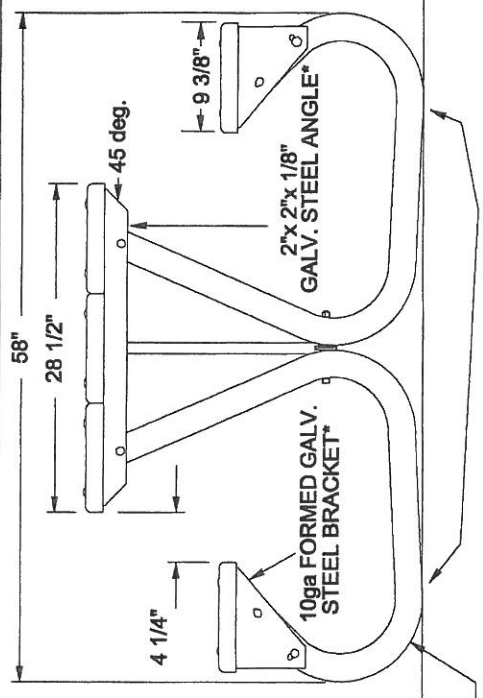

2 3/8" O.D. GALVANIZED HIGH TENSILE TUBE FOR LONGER LIFE.

THE TABLE RESTS ON THE FOUR OUTSIDE CORNERS SO THAT IT WILL NOT ROCK ON UNEVEN GROUND.

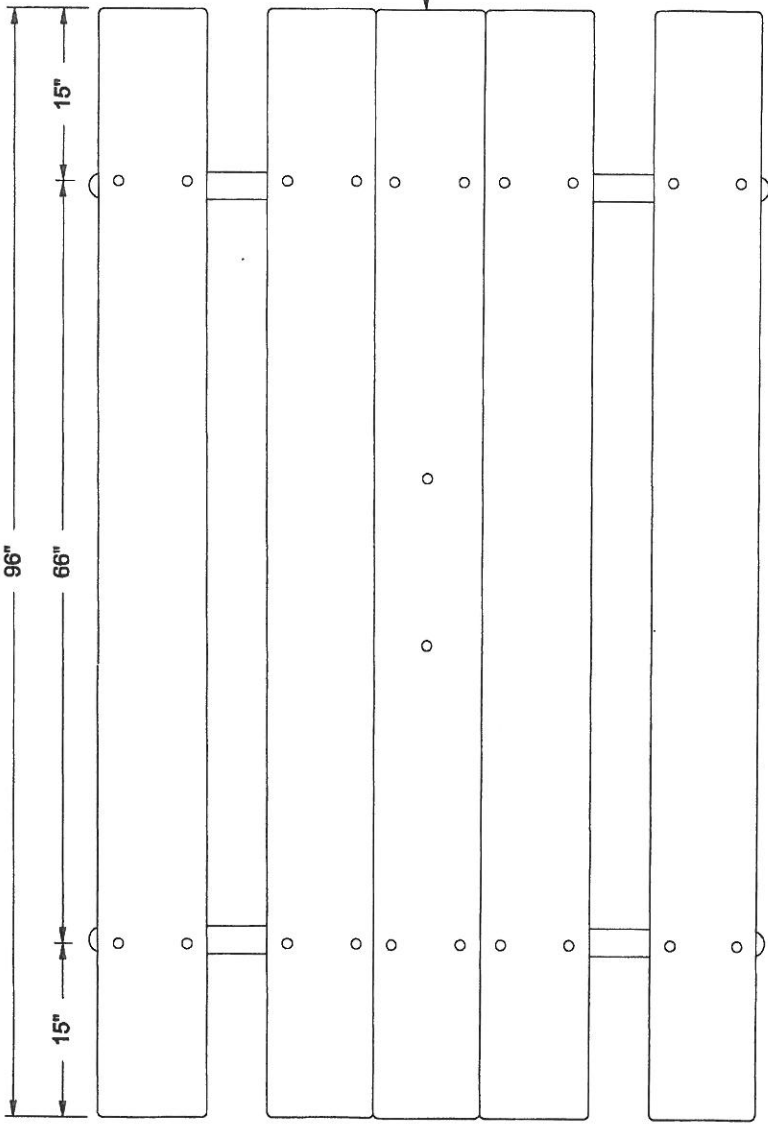

\* SEAT BRACKET & TOP CLEAT ARE GALVANIZED AFTER FABRICATION TO ELIMINATE RAW EDGES LEFT WHEN USING PRE-GALV. SHEETS

\* 2"x 10" No. 1 SOUTHERN YELLOW PINE ACQ TREATED, KDAT WITH EASED EDGES

<b>KAY PARK</b>	
MODEL <b>82BGW</b>	WT. <b>238 lbs.</b>
DRAWN BY LCB	DATE 3/9/98
	SCALE NONE

FILE NAME: 82BGW REV. 1/29/03, CHANGED TOP HEIGHT

# KAY PARK

MODEL **82BGRRP**

WT. **386 lbs.**

DRAWN BY **LCB** DATE **06/04** SCALE **NONE**

FILE NAME: 82BGRRP

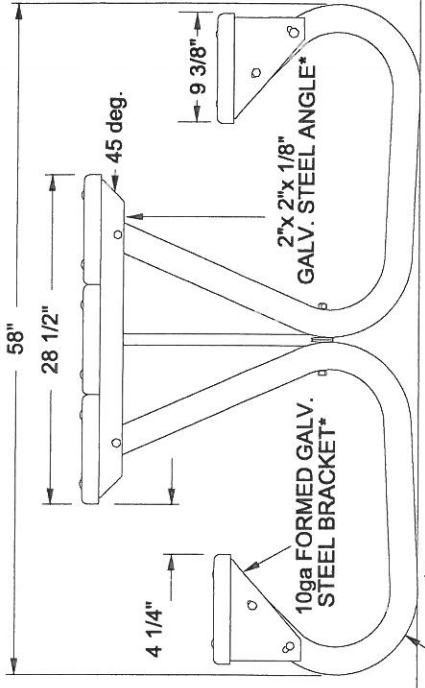

THE TABLE RESTS ON THE FOUR OUTSIDE CORNERS SO THAT IT WILL NOT ROCK ON UNEVEN GROUND.

\* SEAT BRACKET & TOP CLEAT ARE GALVANIZED AFTER FABRICATION TO ELIMINATE RAW EDGES LEFT WHEN USING PRE-GALV. SHEETS

1"x 1" REINFORCING TUBE  
 TOPS PLANKS HAVE ONE TUBE  
 SEAT PLANKS HAVE TWO WELDED TOGETHER

2"x 10" No. Recycled Plastic WITH EASED EDGES

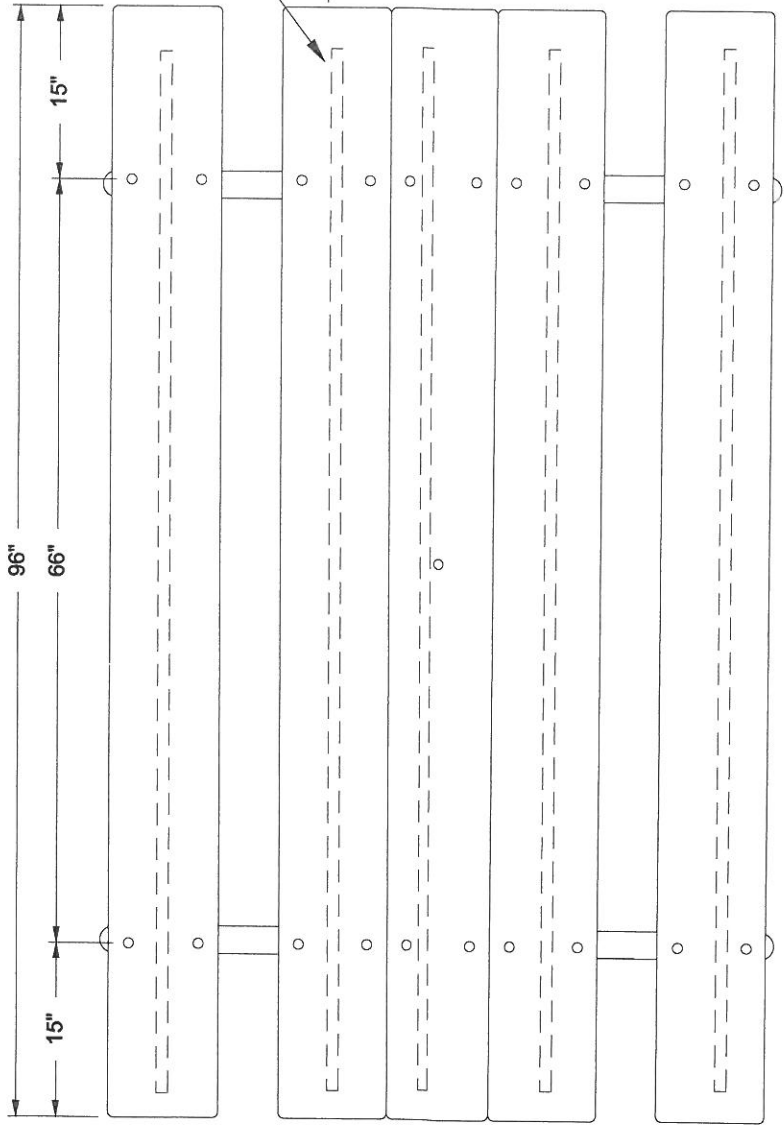
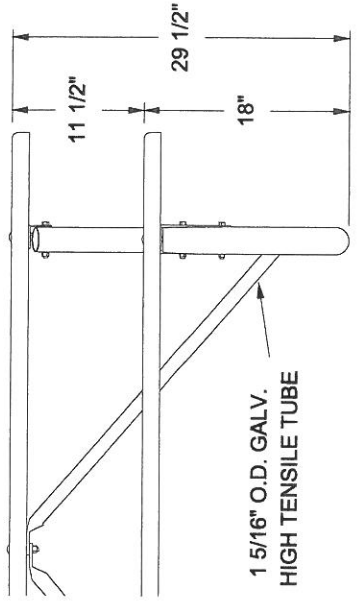

Picnic Tables

Bid opening: April 12, 2016 10:00 a.m.

6 bids received

Tammie Casey, Tim Schwierjohn, Dave Crutchley, Deb Lewis

Contractor	Location	Option 1				Option 2				Total
		Treated Tables	ADA Tables	delivery	Total	Recycled Tables	Treated Tables	ADA Tables	delivery	
1 Fry & Associates	North Kansas City, MO	17,325.00	1,775.00	1,350.00	20,450.00	8,895.00	12,600.00	1,775.00	1,350.00	24,620.00
2 Belson	N Aurora, IL	23,430.00	2,130.00	2,300.11	27,860.11	12,735.00	17,040.00	2,130.00	2,510.19	34,415.19
3 All-Inclusive	Farrington, MO	15,814.15	1,437.65	included	17,251.80	5,998.20	15,995.20	1,999.40	included	23,992.80
4 Highland Products	Boca Raton, FL	20,735.00	1,885.00	600.00	23,220.00	12,690.00	15,080.00	1,885.00	600.00	30,255.00
5 Best Litter Receptacles	Carolina Shores, NC	19,525.00	1,775.00	488.40	21,788.40	11,985.00	14,200.00	1,775.00	488.40	28,448.40
6 Diversified Metal	Smithville, MO	20,625.00	2,050.00	800.00	23,475.00	9,525.00	15,000.00	2,050.00	800.00	27,375.00
7					-					-
8					-					-
9					-					-
10					-					-



**RESOLUTION NO: 16-27**

**A RESOLUTION APPOINTING ANDREW SUTTON TO THE  
POLICE PERSONNEL BOARD**

---

BE IT RESOLVED by the Council of the City of Arnold, Missouri, that Andrew Sutton is hereby appointed to the Police Personnel Board to serve the remainder of a two-year term, terminating on April 30, 2017, or until a successor has been appointed and qualified.

\_\_\_\_\_  
Presiding Officer of the City Council

\_\_\_\_\_  
Mayor Ron Counts

ATTEST:

\_\_\_\_\_  
City Clerk Tammi Casey

Date: \_\_\_\_\_

April 15, 2016

Z:\CITYDOCS\RESOLUTN\16-27 Resolution Appt. Andrew Sutton Police Personnel Board 2016.doc

RESOLUTION NO: 16-28

**A RESOLUTION GRANTING A COOLEY-FULBRIGHT BEAUTIFICAION GRANT  
TO THE RIVER BLUFFS ESTATES SUBDIVISION.**

---

**WHEREAS**, the City of Arnold adopted Resolution No. 13-24 the Cooley-Fulbright City Beautification Program to provide matching grants to subdivisions to help pay for the cost of improving the appearance of a subdivision; and

**WHEREAS**, improving the appearance of the community will enhance the quality of life within neighborhoods and increase property values; and

**WHEREAS**, the River Bluff Estates subdivision has presented the City of Arnold with a request for a grant under Section 1.c.; and

**WHEREAS**, the grant application satisfies all of the requirements of Resolution 13-24;

**NOW, THEREFORE BE IS RESOLVED BY THE CITY COUNCIL OF THE CITY OF  
ARNOLD, MISSOURI AS FOLLOWS:**

The City of Arnold authorizes a Cooley-Fulbright Beautification Program Matching grant to The Arnold Terrace Subdivision up to the amount of \$3,000.00USD pursuant to Resolution No. 13-24 Section 1.c. These monies will be made available as provided for by Resolution.

---

Presiding Officer of the City Council

---

Mayor Ron Counts

ATTEST:

---

City Clerk Tammi Casey

DATE: \_\_\_\_\_

April 18,2016



**The Fountain Division of  
Missouri Machinery and  
Engineering Company**

March 7, 2016

Mr. Glen Portell, Trustee  
River Bluff Estates P.O.A.  
431 Bluffview Heights  
Arnold, Missouri 63010

Re: Floating Fountain Proposal

Dear Glen:

It was a pleasure to meet with you last week to have a look at the pond in your subdivision. Jim Carter of Northwest Electric joined me to determine the best place to access the electrical service and give us a quote on installing the power to the site for the fountain control panel. He has given me his information, and I have included it in the attached proposal.

Also, I have done more measuring of the pond size, and it's actually smaller than I thought. If you measure it from Google Maps (an excellent tool available on the internet) it comes out to be about 1½ acres, so a 3½ horsepower fountain would be sufficient to give good aeration in the pond. The only reason to go higher, would be for the aesthetics. I know it's sometimes difficult to get a consensus with all the homeowners, and the lower cost fountain would make it an easier pill to swallow.

As I explained, we have been selling AquaMaster Fountains for well over 20 years, and have dropped other lines which didn't perform as well as they did. The service and support that we get from the factory personnel is also very valuable to us. Our service technicians are certified by AquaMaster to do field repairs if necessary and they are backed up by the factory. Northwest Electric are experts in their field, as well.

If you have any additional questions, please feel free to contact me. Thanks for your interest in AquaMaster and Hydro Dramatics.

Best regards,

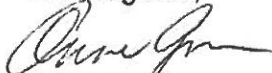
  
Anne Gunn  
Fountain Consultant

Cc: Jim Carter – Northwest Electric

# PROPOSAL

## Hydro Dramatics

The Fountain Division  
of Missouri Machinery  
& Engineering Company

1228 South 8th Street • St. Louis, MO 63104  
Telephone: (314) 231-9806 • Fax: 314-231-5844

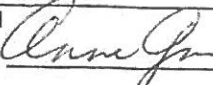
PROPOSAL SUBMITTED TO <b>Riverbluff Estates POA</b>		DATE <b>March 4, 2016</b>	
STREET <b>431 Bluffview Heights</b>		JOB NAME <b>Riverbluff Estates – Floating Fountain</b>	
CITY, STATE AND ZIP CODE <b>Arnold, Missouri 63010</b>		JOB LOCATION <b>Arnold, Missouri</b>	
POINT OF CONTACT <b>Mr. Glen Portell, Trustee</b>	DATE OF PLANS	PHONE <b>636-296-2048</b>	FAX
PAYMENT <b>50% Downpayment; net 30 days.</b>	SHIPMENT/DELIVERY <b>Freight prepaid &amp; allowed to jobsite.</b>	Authorized Signature  <b>Anne Gunn/Fountain Consultant</b>	
Note: This proposal may be withdrawn by us if not accepted within <u>30</u> days.			

**WE PROPOSE** hereby to furnish:

### AquaMaster Masters Series® Floating Fountains

- Float made of linear low density polyethylene with stainless steel hardware and intake screen.
- Precision machined composite impeller and motor shaft of Series 300 stainless steel.
- Impeller housing cast from Nylon type 6 material.
- Motor housing of Series 300 stainless steel, with permanent split phase capacitor on single phase motors and a polyphase induction on three phase motors. Rotor is dynamically balanced and run in a ball bearing supported system. Stator windings are double dipped and baked with a Class F insulation, designed for oil immersion operation. Highly refined, mineral oil of food grade quality, specially formulated for lubrication, and meets FDA regulations. 240V 1PH 60 Hertz 3450 rpm motor, contained in the housing by a Series 300 stainless steel top plate.
- **Five year warranty.**
- Seals made of silicon carbide and stainless steel, meeting UL-778 requirements.
- 250 ft. long Underwater cable is UL listed and designed with a cable strain relief device. Underwater power cable disconnect (UL-778) is located for easy removal for storage or maintenance.
- Crown & Geyser nozzle included in price. Nozzles are interchangeable with stainless steel thumb screw fasteners – no tools required.
- NEMA 3R Electrical enclosure, galvanized and powder-coated gray, lock and mount capable. Contains: GFCI breaker, control breaker, motor contactor, overload assembly and timer, UL approved.

## CONTINUED

3 1/2 HP

5 HP

Price.....\$ 7,140.00

\$ 9,205.00

**Prices above are for equipment only, and do not include installation.**

**Price does not include state sales tax, if applicable.**

**Fountain Installation –**

Hydro Dramatics will deliver fountain to site, position into lake, connect power to panel, connect fountain cable to panel, start & test. Price does not include any trenching, digging or backfilling. Lake must be approachable by service truck. (2 service technicians/1 day)

Installation price.....\$ 1,500.00

**Northwest Electric Site preparation –**

Service: Includes labor and material to install steel rack approximately 20' from lake, wire and install 100amp combination meter and waterproof panel on steel rack.

Trenching: Includes labor and equipment to trench approx.. 75' from Ameren pedestal between houses 2220 & 2226 on River Bluff Dr. to combination meter & waterproof panel by lake, install 2 1/2" PVC conduit and #2 aluminum URD cable from Ameren transformer to electric meter.

Fountain: Install control panel for fountain on rack, wire and install 1 – 40amp 240V 1PH circuit from waterproof panel to control panel. Install 1 run of 2 1/2" PVC conduit from control panel into lake, beneath water level.

**Clarifications:**

- All work to be done during normal business hours, Mon-Fri, 7am to 3:30pm
- All wiring to be in compliance with the latest edition of the National Electric Code.
- Price subject to change if done completed by 6/30/16
- Northwest Electric to furnish electrical permit
- Any charges from Ameren to be paid by others

Electrical installation price.....\$ 6,200.00

<p><b>ACCEPTANCE OF PROPOSAL</b> – The above prices, specifications and conditions are satisfactory and are hereby accepted. You are authorized to do the work as specified. Payment will be made as outlined above.</p>	<p>_____</p> <p>Signature <span style="float: right;">Date</span></p>
--	---

## TERMS AND CONDITIONS

All material is guaranteed to be as specified. All work to be completed in a professional manner according to standard practices. Any alteration or deviation from specifications noted on the front involving extra costs will be executed only upon written orders, and will become an extra charge over and above the estimate. All agreements contingent upon strikes, accidents or delays beyond our control. Owner to carry fire, tornado and other necessary insurance. Our workers are covered by Worker's Compensation.

### FORMATION OF CONTRACT AND MODIFICATIONS

All orders are subject to acceptance by Seller, are not valid unless officially acknowledged in writing by Seller and are subject to correction of stenographic errors. The Seller's Proposal, Buyer's Acceptance and Seller's Sales Order Acknowledgment shall constitute the entire contract between Buyer and Seller. This contract supercedes any and all prior negotiations and any oral agreement or written agreement made or sent relating to this sale to Buyer of any product described herein. This contract may not be altered or amended except by writing signed by both Seller and Buyer. Seller specifically objects to the inclusion of any additional or different terms and Buyer's acceptance of the offer made in the proposal and to the inclusion of any additional or different terms from those stated in Seller's Sales Order Acknowledgment. Failure of Seller to exercise any of Seller's rights under this contract upon one occasion shall not waive Seller's right to exercise the same on another occasion. Agents and sales representatives of seller have no authority to make any representations not included herein, and any such representations should not be relied on by Buyer.

### PRICE:

Unless otherwise noted, all prices are exclusive of any sales or use tax which are now in force or may be made effective in the future by any local, state or federal government. Buyer will pay all such taxes.

### PAYMENT TERMS:

Unless otherwise noted on the reverse hereof, Seller's terms are 30 days net from invoice date. A late payment charge equal to 1 1/2% per month (18% Annual Rate) will be assessed on the balance of all accounts more than 30 days past due. Buyer agrees to pay all costs, including attorney's fees, arising from the collection of past due accounts. If Buyer fails to pay any invoice when due or otherwise fails to pay any invoice in accordance with the terms which it owes to Seller, Seller may defer shipment, alter payment terms or terminate any contract resulting from Seller's Proposal. Buyer's acceptance and Seller's Sales Order Acknowledgment. Seller may require cash payment or satisfactory security for future deliveries if Buyer's financial responsibility becomes unsatisfactory to Seller, or it Buyer fails to pay any invoice when due.

### COMMERCIAL IMPRACTICABILITY:

Seller shall not be liable to Buyer should performance hereunder become commercially impracticable due to any contingency beyond Seller's reasonable control, including, without limitation, acts of God, fires, floods, wars, sabotage, civil unrest, accidents, labor disputes or shortages, governmental laws, ordinances, rules and regulations, whether valid or invalid (including, without limitation, priorities, requisitions, allocation in price adjustment restrictions), inability to obtain material, equipment or transportation, incorrect, delayed or incomplete specifications, drawings or data supplied by Buyer or others, or any similar or different contingency. In no event shall Seller be obligated to purchase goods from others to enable it to deliver pursuant to any contract.

### BREACH OF CONTRACT:

In the event of any breach or cancellation by Buyer of any contract, Buyer shall pay all damages, expenses, and losses, direct or indirect, including attorney's fees and costs of collection, incurred by Seller. In addition, upon cancellation by Buyer, Buyer shall pay all engineering, labor and material costs incurred by Seller.

### SHIPMENT TERMS:

Shipments are F.O.B. Seller's place of business. Unless otherwise agreed upon on the reverse hereof, transportation expenses are prepaid and charged to Buyer. Title and risk of loss on all goods sold hereunder shall pass to Buyer upon Seller's delivery to carrier at shipping point. Seller may ship the goods in any commercially reasonable way, and Seller shall not be responsible for selecting the least expensive or fastest routing. Transportation damage must be claimed against the carrier by Buyer. All delivery information and shipping dates are estimated and Seller shall not assume any liability for damages, consequential, incidental or otherwise resulting from any delays that may occur.

In the event that Buyer requests or instructs that a shipment be delayed beyond the date agreed upon, Buyer shall pay for all transportation and storage charges, together with any extra handling costs and all other expenses Seller incurred by reason of any such delay.

### NEW EQUIPMENT AND PARTS - LIMITED WARRANTY

New equipment and parts are not manufactured by Seller. Seller does not make any representation or warranty, expressed or implied, as to the new equipment or parts provided by the manufacturer. INCLUDING, WITHOUT LIMITATION, ANY WARRANTIES OR MERCHANTABILITY OR FITNESS FOR A PARTICULAR PURPOSE. AS TO NEW EQUIPMENT AND PARTS, ANY WARRANTY EITHER EXPRESSED OR IMPLIED, INCLUDING WITHOUT LIMITATION ANY EXPRESSED OR IMPLIED WARRANTY OF MERCHANTABILITY OR FITNESS FOR A PARTICULAR PURPOSE IS LIMITED TO THE MANUFACTURER'S WRITTEN WARRANTY, IF ANY. Copies of such written warranties will be available to Buyer upon request. Under no circumstances and in no event shall Seller be liable for incidental or consequential damages for lost profits, lost sales, injuries to persons or property, or any other incidental, consequential, special, indirect or exemplary damages of any kind.

### USED EQUIPMENT PARTS - DISCLAIMER OF ALL WARRANTIES:

ALL USED EQUIPMENT AND PARTS ARE SOLD AS IS AND WITH ALL FAULTS AND WITHOUT ANY WARRANTY EITHER EXPRESSED OR IMPLIED, INCLUDING, WITHOUT LIMITATION, ANY WARRANTIES OR MERCHANTABILITY OR FITNESS FOR A PARTICULAR PURPOSE. Under no circumstances and in no event shall Seller be liable for incidental or consequential damages for lost profits, lost sales, injury to persons or property, or any other incidental, consequential, special, indirect or exemplary damages of any kind.

### FLOATING FOUNTAINS - LIMITED WARRANTY:

Seller warrants only the floating fountains against defects in material and workmanship appearing to Buyer within one year of delivery and communicated in writing to Seller no later than 13 months from the date of delivery. Within a reasonable time after such notification, Seller will repair the merchandise, using either new or replacement parts, or replace the merchandise. If Seller is unable to repair the merchandise after a reasonable number of attempts, Seller will provide either a refund of the purchase price or a replacement unit at Seller's discretion. This warranty includes only parts and labor for repairs, or replacement, if necessary. Seller in no case shall be liable for service time, travel expenses, transportation and shipping costs and removal and reinstallation of merchandise; all such costs shall be borne by Buyer. Seller shall have no warranty obligation under this contract if the merchandise has been subjected to abuse, misuse, negligence, accident, improper service, improper installation (unless performed by Seller) or damaged during shipment. There are no other warranties which extend beyond the description on the face hereof and the warranty described in this paragraph shall be IN LIEU OF ANY OTHER WARRANTY, EXPRESSED OR IMPLIED, INCLUDING WITHOUT LIMITATION, ANY IMPLIED WARRANTY OF MERCHANTABILITY, OR FITNESS FOR A PARTICULAR PURPOSE, SELLER AND BUYER UNDERSTAND AND AGREE THAT BUYER'S SOLE AND EXCLUSIVE REMEDY AGAINST SELLER SHALL BE FOR THE REPAIR OR REPLACEMENT OF DEFECTIVE MERCHANDISE OR A REFUND OF THE PURCHASE PRICE AT THE SELLER'S DISCRETION. Buyer understands and agrees that no other remedy including, but not limited to, incidental or consequential damages for loss of profits, loss of sales, injuries to persons or property, or any other incidental or consequential loss shall be available to buyer.

### LIMITED WARRANTY - REPAIRS:

Seller warrants that repairs performed by Seller shall be free from defects and workmanship for 90 days from delivery to Buyer. This warranty applies only to repairs performed by Seller. This warranty does not apply to merchandise which has been subjected to abuse, misuse, negligence, accident, improper service, improper installation (unless performed by Seller) or damaged during shipment. This warranty includes parts and labor for repairs only. In no case shall Seller be liable for service time, travel expenses, transportation and shipping costs and removal and reinstallation of merchandise. There are no other warranties which extend beyond the description on the face hereof and the warranties described in this paragraph shall be IN LIEU OF ANY OTHER WARRANTY, EXPRESSED OR IMPLIED, INCLUDING WITHOUT LIMITATION, ANY IMPLIED WARRANTY OF MERCHANTABILITY, OR FITNESS FOR A PARTICULAR PURPOSE. Seller and Buyer agree that Buyer's sole and exclusive remedy against Seller shall be for the repair or replacement of defective parts. Buyer understands and agrees that no other remedy including, but not limited to, incidental or consequential damages for loss of profits, loss of sales, injuries to persons or property, or any other incidental or consequential loss shall be available to Buyer.

### ELECTRICAL FOUNTAIN EQUIPMENT:

All electrical fountain equipment will be installed in compliance with Section 680 of the National Electrical Code and all Code requirements. This shall include the use of ground fault circuit interrupters on each branch circuit underwater electrical fountain equipment above 15 volts.

### GOVERNING LAW:

This contract shall be governed by and construed in accordance with the Uniform Commercial Code as in effect in Missouri, except as provisions of such Code are herein modified.

### NOTICE TO OWNERS:

Failure of this contractor to pay those persons supplying material or services to complete this contract can result in the filing of a mechanic's lien on the property which is the subject of this contract pursuant to Chapter 429, RSMO. To avoid this result you may ask this contractor for "lien waivers" from all persons supplying material or services for the work described in this contract. Failure to secure lien waivers may result in your paying for labor and material twice.